



Government
of Canada

Gouvernement
du Canada

Canadian General
Standards Board

Office des normes
générales du Canada

CAN/CGSB-65.16-2005

Supersedes CAN/CGSB-65.16-99

Immersion Suit Systems

ICS 13.340.10

National Standard of Canada

The CANADIAN GENERAL STANDARDS BOARD (CGSB), under whose auspices this National Standard of Canada has been developed is a government agency within Public Works and Government Services Canada. CGSB is engaged in the production of voluntary standards in a wide range of subject areas through the media of standards committees and the consensus process. The standards committees are composed of representatives of relevant interests including producers, consumers and other users, retailers, governments, educational institutions, technical, professional and trade societies, and research and testing organizations. Any given standard is developed on the consensus of views expressed by such representatives.

CGSB has been accredited by the Standards Council of Canada as a national standards-development organization. The standards that it develops and offers as National Standards of Canada conform to the criteria and procedures established for this purpose by the Standards Council of Canada. In addition to standards it publishes as national standards, CGSB produces standards to meet particular needs, in response to requests from a variety of sources in both the public and private sectors. Both CGSB standards and CGSB national standards are developed in conformance with the policies described in the CGSB Policy Manual for the Development and Review of Standards.

CGSB standards are subject to review and revision to ensure that they keep abreast of technological progress. Suggestions for their improvement, which are always welcome, should be brought to the notice of the standards committees concerned. Changes to standards are issued either as separate amendment sheets or in new editions of standards.

An up-to-date listing of CGSB standards, including details on latest issues and amendments, and ordering instructions, is found in the CGSB Catalogue, which is published annually and is available without charge upon request. An electronic version, ECAT, is also available. More information is available about CGSB products and services at our Web site — www.ongc-cgsb.gc.ca.

Although the intended primary application of this standard is stated in its Scope, it is important to note that it remains the responsibility of the users of the standard to judge its suitability for their particular purpose.

The testing and evaluation of a product against this standard may require the use of materials and/or equipment that could be hazardous. This document does not purport to address all the safety aspects associated with its use. Anyone using this standard has the responsibility to consult the appropriate authorities and to establish appropriate health and safety practices in conjunction with any applicable regulatory requirements prior to its use. CGSB neither assumes nor accepts any responsibility for any injury or damage that may occur during or as the result of tests, wherever performed.

Attention is drawn to the possibility that some of the elements of this Canadian standard may be the subject of patent rights. CGSB shall not be held responsible for identifying any or all such patent rights. Users of this standard are expressly advised that determination of the validity of any such patent rights are entirely their own responsibility.

Further information on CGSB and its services and standards may be obtained from:

The Manager
Strategic Standardization Division
Canadian General Standards Board
Gatineau, Canada
K1A 1G6

The STANDARDS COUNCIL OF CANADA is the co-ordinating body of the National Standards System, a federation of independent, autonomous organizations working towards the further development and improvement of voluntary standardization in the national interest.

The principal objectives of the Council are to foster and promote voluntary standardization as a means of advancing the national economy, benefiting the health, safety and welfare of the public, assisting and protecting the consumer, facilitating domestic and international trade, and furthering international co-operation in the field of standards.

A National Standard of Canada is a standard which has been approved by the Standards Council of Canada and one which reflects a reasonable agreement among the views of a number of capable individuals whose collective interests provide, to the greatest practicable extent, a balance of representation of producers, users, consumers and others with relevant interests, as may be appropriate to the subject in hand. It normally is a standard that is capable of making a significant and timely contribution to the national interest.

Approval of a standard as a National Standard of Canada indicates that a standard conforms to the criteria and procedures established by the Standards Council of Canada. Approval does not refer to the technical content of the standard; this remains the continuing responsibility of the accredited standards-development organization.

Those who have a need to apply standards are encouraged to use National Standards of Canada whenever practicable. These standards are subject to periodic review; therefore, users are cautioned to obtain the latest edition from the organization preparing the standard.

The responsibility for approving National Standards of Canada rests with the:

Standards Council of Canada
270 Albert Street
Suite 200
Ottawa, Ontario
K1P 6N7

How to order **CGSB** Publications:

- by telephone — (819) 956-0425 *or*
— 1-800-665-2472
- by fax — (819) 956-5644
- by mail — CGSB Sales Centre
Gatineau, Canada
K1A 1G6
- in person — Place du Portage
Phase III, 6B1
11 Laurier Street
Gatineau, Quebec
- by email — ncr.cgsb-ongc@pwgsc.gc.ca
- on the Web — www.ongc-cgsb.gc.ca

IMMERSION SUIT SYSTEMS

Prepared by the

Canadian General Standards Board 

Approved by the

Standards Council of Canada 

Published November 2005 by the
Canadian General Standards Board
Gatineau, Canada K1A 1G6

© HER MAJESTY THE QUEEN IN RIGHT OF CANADA
as represented by the Minister of Public Works and Government Services,
the Minister responsible for the Canadian General Standards Board, (2005)

No part of this publication may be reproduced in any form without the prior permission of the publisher.

CANADIAN GENERAL STANDARDS BOARD
COMMITTEE ON IMMERSION SUITS

(Membership at date of approval)

Brooks, C.J.	<i>Chairperson</i>	Survival Systems Ltd.
Anderson, J.D.		National Energy Board
Barnes, P.		Canadian Association of Petroleum Producers
Belzile, F.		Transport Canada
Bohemier, A.		Survival Systems Ltd.
Boone, J.		Kerwin Place
Cariou, C.		ExxonMobil Canada Properties
Chafe, G.		Fishermen, Food and Allied Workers Union
Dobson, M.		United Food and Commercial Workers Union, Local 864
Dunphy, K.		Government of Newfoundland and Labrador
Frauts, J.		Ministry of Labour, Ontario
Ireland, R.		Helicopter Survival Rescue Services Inc.
Jackson, D.		Fitzwright Company Ltd.
Johnston, P.		Associated Marine Equipment Ltd.
Johnston, R.		Protexion Products Inc.
Kearns, C.		Stearns Inc.
Khouzam, M.		Transport Canada
Lee, M.		Mustang Survival Corporation
Meloche, Capt K.		National Defence
Neaves, D.R.		Helly-Hansen (Canada) Ltd.
Noel, P.		Canada/Newfoundland Offshore Petroleum Board
Potter, P.		The Cord Group Ltd.
Roberts, C.		Small Fishing Vessels Safety Committee
Scratch, D.		Canada–Nova Scotia Offshore Petroleum Board
Therien, E.		Canada Safety Council
Thomas, D.		DSS Marine Inc.
Toshack, D.		Underwriters' Laboratories of Canada
Trottier, J.-M.		Canadian Coast Guard
Wagner, S.		Salus Marine Wear Inc.
White, F.		Whites Manufacturing Ltd.
Wright, G.R.		City of Vancouver
Khan, R.	<i>Secretary</i>	Canadian General Standards Board

Acknowledgment is made for the translation of this National Standard of Canada by the Translation Bureau of Public Works and Government Services Canada.

FOREWORD

This standard has been incorporated by reference in the *Life Saving Equipment Regulations* made pursuant to the *Canada Shipping Act*. Where there are differences between the requirements of the *Life Saving Equipment Regulations* and this standard, the *Life Saving Equipment Regulations* shall prevail.

For approval requirements, the reader must refer to the approval authority, Transport Canada, Marine Safety.

CANADIAN GENERAL STANDARDS BOARD**IMMERSION SUIT SYSTEMS****1. SCOPE**

- 1.1 This standard applies to immersion suit systems for marine abandonment and constant wear. This standard applies to suit systems that reduce thermal shock upon entry into cold water; delay the onset of hypothermia during immersion in cold water; provide acceptable flotation and minimize the risk of drowning; do not impair the wearer's ability to perform fundamental survival actions; and, in the case of constant wear immersion suits, do not impair the wearer's ability to perform normal working duties.
- 1.2 The testing and evaluation of a product against this standard may require the use of materials and/or equipment that could be hazardous. This document does not purport to address all the safety aspects associated with its use. Anyone using this standard has the responsibility to consult the appropriate authorities and to establish appropriate health and safety practices in conjunction with any applicable regulatory requirements prior to its use.

2. REFERENCED PUBLICATIONS

- 2.1 The following publications are referenced in this standard:

2.1.1 Canadian General Standards Board (CGSB)

3-GP-11d (2002) — Naval Distillate Fuel

3-GP-691c (1995) — General Purpose Grease

CAN/CGSB-4.2 — Textile Test Methods:

No. 9.2-M90 — Breaking Strength of Fabrics — Grab Method — Constant time-to-break Principle

No. 26.1-M88 — Water Resistance — Static Head Penetration Test

No. 32.2-M89 — Breaking Strength of Seams in Woven Fabrics.

CAN/CGSB-54.1-M90, Part 1/ISO 4915:1981 — Stitches and Seams — Part I: Textiles — Stitch Types — Classification and Terminology

CAN/CGSB-65.18-M86 — Closed-Cell Foamed Polymeric Materials

CAN/CGSB-65.19-2004 — Textile Components of Life Jackets and Personal Flotation Devices.

2.1.2 ASTM International

B 21/B 21M-01e1 — Standard Specification for Naval Brass Rod, Bar, and Shapes

B 117-03 — Standard Practice for Operating Salt Spray (Fog) Apparatus

C 177-04 — Standard Test Method for Steady-State Heat Flux Measurements and Thermal Transmission Properties by Means of the Guarded-Hot-Plate-Apparatus

C 518-04 — Standard Test Method for Steady-State Thermal Transmission Properties by Means of the Heat Flow Meter Apparatus

D 2062-87(1997) e1 — Standard Test Methods for Operability of Zippers

D 3886-99 — Standard Test Method for Abrasion Resistance of Textile Fabrics (Inflated Diaphragm Method).

2.1.3 European Committee for Standards (CEN)

EN 1095:1998 — Deck safety harness and safety line for use on recreational craft — Safety requirements and test methods.

- 2.1.4 International Maritime Organization (IMO)
Resolution A.658(16) — Use and fitting of retroreflective materials on life-saving appliances
Resolution A.760(18) — Symbols related to life-saving appliances and arrangements
Resolution MSC.48(66) — International Life-Saving Appliances Code, 2003
Resolution MSC.81(70) — Testing and Evaluation of Life-Saving Appliances.
- 2.1.5 Underwriters Laboratories Inc. (UL)
UL 1123-1996 — Marine Buoyant Devices
UL 1180-2004 — Fully Inflatable Recreational Personal Flotation Devices
UL 1191-1997 — Components for Personal Flotation Devices
UL 1197-1996 — Immersion Suits.
- 2.2 A dated reference in this standard is to the issue specified. An undated reference in this standard is to the latest issue, unless otherwise specified by the authority applying this standard. The sources are given in the Notes section.

3. DEFINITIONS

- 3.1 The following definitions apply in this standard:

Abandonment Suit (Combinaison en cas de naufrage)

An immersion suit, designed to permit rapid donning in the event of an imminent unintended immersion in water.

Auxiliary Buoyancy Element (Élément de flottaison auxiliaire)

A source of buoyancy additional to the suit system's inherent buoyancy.

Buddy Line (Corde d'assurance)

A length of cord which can be tied or otherwise fixed to another person's suit, or lifejacket, or to a life raft or other objects, so as to keep the wearer in the vicinity of that person or object with a view of making location and thus rescue easier.

Clo Value (Valeur clo)

An index of clothing insulation. One clo equals $0.155^{\circ}\text{C}\cdot\text{m}^2\cdot\text{W}^{-1}$.

Constant Wear Suit (Combinaison de bord)

An immersion suit, designed to be routinely worn for activities on or near water in anticipation of accidental immersion in water, but permitting physical activity by the wearer to such an extent that actions may be undertaken without undue encumbrance.

Design Buoyancy (Flottabilité nominale)

The actual buoyancy of the device, including compression loss factors and manufacturing tolerance allowance.

Exterior Fabric (Tissu extérieur)

The outer fabric of the suit system, either in the form of a single or composite fabric.

Face-Plane Angle (Angle du plan facial)

The angle relative to the surface of the water, of the plane formed by the most forward part of the forehead and the chin.

Freeboard (Franc bord d'émergence)

The perpendicular distances from the surface of the water to the corner of the mouth.

Immersed Clo Value (Clo en état d'immersion)

The insulation measurement taken when a suit system is subjected to the effect of hydrostatic compression.

Inflatable Buoyancy Element (Élément de flottaison gonflable)

An auxiliary buoyancy element that requires gas inflation as a means of buoyancy.

Minimum Buoyancy (Flottabilité minimum)

The minimum amount of buoyancy that must be provided by inherently buoyant materials.

Primary Suit System Closures (Principaux dispositifs de fermeture de la combinaison)

Any closures utilized in the donning of the suit system for normal work purposes.

Retroreflective Material (Matériau rétroréfléchissant)

A material that reflects light beams back to their point of origin.

Secondary Suit System Closures (Dispositifs complémentaires de fermeture de la combinaison)

Additional closures that may be operated by the wearer in the water.

Sprayhood (Dispositif anti-éclaboussures)

A cover brought or placed in front of the face of the wearer in order to reduce or eliminate the splashing of water onto the airways, and thereby promoting the survival of the wearer in rough water conditions.

Structural Seam (Couture structurale)

A seam that the structural integrity of the suit system relies upon.

Total Buoyancy (Flottabilité totale)

The total buoyancy available to the wearer from all elements of the suit system, excluding accidentally entrapped air. This includes the minimum inherent buoyancy and the auxiliary buoyancy.

V-factor (Facteur V)

An expression of the buoyancy retention of polymeric materials intended for use in suit systems, life jackets and personal flotation devices.

4. CLASSIFICATION

4.1 The immersion suit systems shall be supplied in the following categories and sizes:

4.1.1 **Categories**

Category 1 — Marine Abandonment

Category 2 — Constant Wear

4.1.2 **Sizes**

4.1.2.1 *Marine Abandonment* — Marine Abandonment Immersion Suit Systems shall be supplied in adult and child sizes as listed in the body heights and mass ranges, as specified in Table 1.

TABLE 1**Marine Abandonment Immersion Suit Sizes**

Size	Body Height cm	Body Mass kg
Adult:		
Small	120 to 170	40 to 100
Universal	150 to 200	50 to 150
Jumbo	170 to 220	100 to 150 or greater
Custom	Any height	Any mass
Child	100 to 150	18 to 40

- 4.1.2.2 *Constant Wear* — Constant Wear Immersion Suit Systems shall be supplied in multiple adult and child sizes covering the body mass ranges, as specified in Table 2.

TABLE 2**Constant Wear Immersion Suit Sizes**

Size	Body Mass kg
Adult	Over 40
Child	18 to 40

- 4.1.2.3 *Sizes* — There are important distinctions between “Universal” sized suits and suits that have a specific size range (Small, Jumbo, Custom and Child Marine Abandonment Suits and all Constant Wear Suits. “Universal” suits are for general and unspecified users and are designed with a “One size fits most” approach. Such suits are suitable for uncontrolled distribution in emergency situations. Suits with a reduced size range are designated for a specific segment of the population and are required to be clearly identified to prevent inadvertent selection in emergency situations. The marking section (par. 8.5) of this standard incorporates requirements that reflect the distinction between “Universal” size suits and suits that have a specific size range.

5. GENERAL REQUIREMENTS

- 5.1 As suit systems will be used by uninitiated persons, often in adverse conditions, it is essential that risk of incorrect donning be minimized. Ties and fastenings necessary for proper performance should be few and simple. Marine Abandonment Immersion Suit Systems should readily fit various sizes of adults and children, both lightly and heavily clad.
- 5.2 The suit system may be composed of one or more pieces, provided that in all cases it meets the requirements of this standard as a complete system. The suit system shall be constructed so that it is suitable for use in a working industrial environment when properly worn and secured.
- 5.3 **Hand and Arm Construction** — Gloves or mittens may be either integral with the suit system or removable and attached to the suit system. In either case, the wearer shall retain sufficient dexterity to pass the dexterity tests, and the wearer’s escape or survival ability shall not be hindered or reduced. If the hand can be exposed, the watertight integrity of the suit system (dry suit system only) shall be maintained. (Test procedures: par. 6.11, 6.12 and 6.14.)
- 5.4 **Leg Construction** — Each suit system leg shall be fitted with a foot in which there is a hard sole or enough room for a work shoe to be worn inside. The sole shall prevent the wearer from slipping. (Test procedure: par. 6.15.)

- 5.5 **Closures and Seals** — Each closure, seal and zipper shall be durable and constructed to be donned with ease and secured while fulfilling all other requirements specified in this standard. If the suit system (dry suit system only) contains elements that may be detached by the wearer, the general water integrity of the suit system shall be maintained when any such element is detached. All seals (i.e. face, neck, wrist and foot) shall be comfortable. (Test procedures: par. 6.8, 6.9 and 6.10.)
- 5.6 **Sprayhood** — The fitting of a sprayhood is optional but if fitted must comply with par. 6.21.
- 5.7 **Workmanship** — The suit system shall be free from defects in workmanship and materials that might affect its strength, serviceability, or appearance.
- 5.8 **Operational Temperature** — The suit system shall operate throughout the seawater temperature range of -1 to +30°C. The suit system shall withstand stowage throughout an air temperature range of -30 to +65°C. (Test procedures: par. 6.2, 6.9 and 6.22.)
- 5.9 **Materials** — The suit system shall be rot-proof, corrosion-resistant, and shall not be unduly affected by seawater, oil or fungal attack. The exterior fabric shall be resistant to puncture, tearing and abrasion. The suit system shall be capable of being readily cleaned. The suit system, where exposed to sunlight, shall be resistant to deterioration. (Test procedure: par. 6.3.)
- 5.10 **Colour** — To assist detection, the exterior fabric of the suit system shall be a red, orange, or yellow colour.
- 5.11 **Buoyancy** — The suit system shall provide buoyancy for flotation. (Test procedures: par. 6.4 and 6.5.)
- 5.12 **Donning Time** — The suit system shall be unpacked and donned without assistance within 2 min. (Test procedures: par. 6.8 and 6.9.)
- 5.13 **Flame Resistance** — The performance of the suit system shall not be affected after being enveloped in a fire for a period of 2 s. (Test procedure: par. 6.6.)
- 5.14 **Radio Pocket** — A pocket shall be attached to the front of the suit system that can house a portable radio. It shall be easily accessible and securable by either hand to stow or withdraw the radio.
- 5.15 **Field of Vision** — The suit system, when worn in or out of the water, shall have minimal affect on the wearer's visual fields. (Test procedure: par. 6.18.)
- 5.16 **Free Ends** — Drawstrings, hook and pile fasteners, belts, buckles, or other primary or secondary closure devices used on the suit system shall be designed to minimize the risk of snagging. (Test procedure: par. 6.23.)
- 5.17 **Personal Locator Light** — Each suit system shall be fitted with a personal locator light meeting the requirements of the IMO Resolution MSC.81(70). The light location shall be above the water level when the wearer is in the water.
- 5.18 **Personal Whistle** — Each suit system shall be fitted with a whistle firmly secured by a cord. It shall be easily accessible by either hand when the suit system is worn on land or in the water.
- 5.19 **Storage** — Each Marine Abandonment Immersion Suit System shall be supplied with a storage container that provides protection for the suit system. Constant Wear Immersion Suit Systems do not require a storage container.
- 5.20 **Repairs** — In case of damage that might affect the buoyancy or thermal properties of the suit system, repairs shall
- a. be performed by the manufacturer of the suit system or any repair facility authorized by the manufacturer; and
 - b. meet the construction and performance requirements of this standard.

6. DETAILED REQUIREMENTS

6.1 Construction Detail

6.1.1 **Body Strength** — When a force of not less than 1350 N is applied to the part of the suit system that secures it to the body of the wearer, the suit system shall not be damaged, tear or break, or its performance degraded as a result.

6.1.1.1 **Body Strength Test** — The body strength of the suit system shall be tested under the following conditions and procedures:

6.1.1.1.1 **Body Strength Test Equipment** — The test apparatus shown in Figure 1 shall be used in this test. It consists of

- a. two rigid cylinders, each 125 mm in diameter, with an eye or ring at each end;
- b. a mass of 138 kg; and
- c. ropes or cables of sufficient length to allow the suit system to be suspended.

6.1.1.1.2 **Body Strength Test Procedure** — Cut the suit system at the waist and wrists or cut holes into it as necessary to accommodate the test apparatus. Immerse the suit system in water for at least 2 min. Next, remove the suit system from the water and immediately arrange it on the test apparatus, using each closure as it would be used by a person wearing the suit system. Apply the 1350 N load for 5 min.

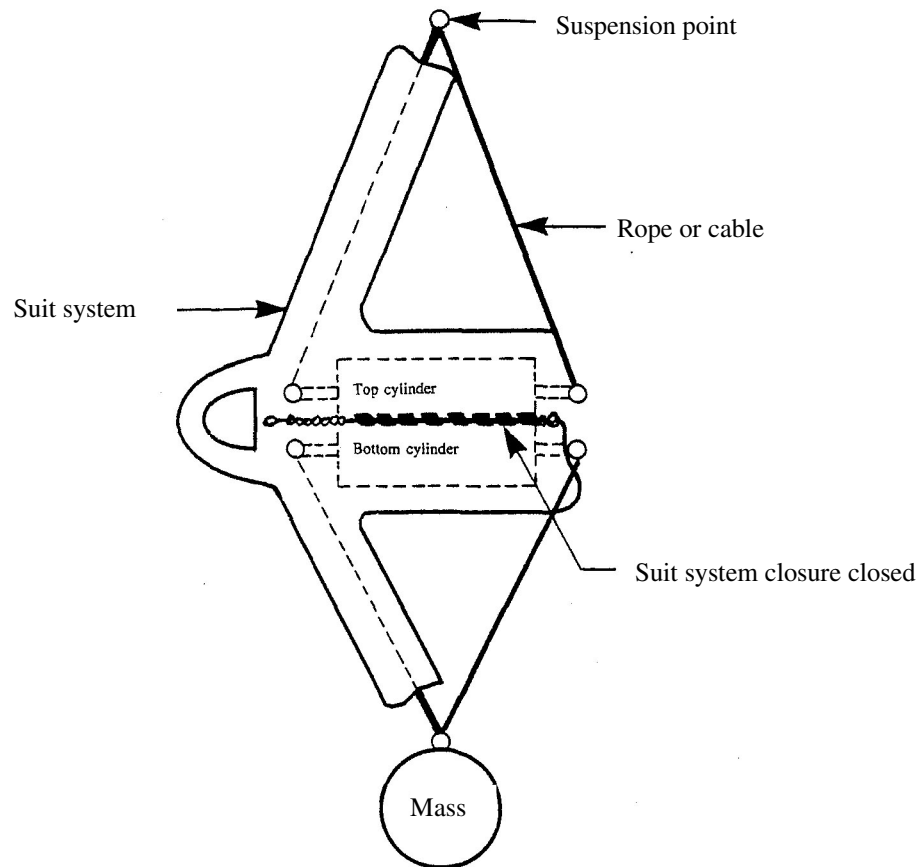

FIGURE 1
Body Strength Apparatus

6.1.2 **Fittings** — The size and design of additional fittings and their attachment to the suit system shall allow for ease of use of the fittings. The fittings shall be attached in such a way that they are visually and physically accessible and operable. They shall not attain a position that either degrades the function of the fittings or reduces the wearer's ability to escape or survive.

- 6.1.3 **Attachment Strength of Closure Systems** — Where the design of the closure involves the attachment of parts or components (e.g. straps, cords, etc.), it shall have a strength of 222 N.
- 6.1.3.1 **Attachment Strength of Closure Systems Test** — Apply a static load of 222 N to the closure system attachment parts or components for 1 min. There shall be no evidence of damage or failure upon visual examination subsequent to this test.
- 6.1.4 **Seams**
- 6.1.4.1 **Seam Slippage** — All structural seams shall be stitched with 7 to 10 lock stitches per 25 mm, stitch type 301 for fabric materials or stitch type 101 for neoprene materials (see CAN/CGSB-54.1-M90, Part 1/ISO 4915:1981). Other construction methods may be used if they can be demonstrated to meet the seam strength requirements outlined in this standard.
- 6.1.4.2 **Strength of Seams** — The minimum strength of seams shall be 360 N for exterior seams and 285 N for lining seams when tested in accordance with CAN/CGSB-4.2 No. 32.2-M89. Seams shall be deliberately positioned to assist in developing the full strength of the exterior shell. Seams shall be of a type that does not expose any raw edges.
- 6.1.4.2.1 **Strength of Seams Test** — Obtain ten samples, each 100 mm wide and at least 150 mm long, with the seam to be tested at right angles to the length and approximately equidistant from the ends of the sample. Five samples shall have the seams on the warp, and five samples shall have the seams on the weft. Immerse each sample in water at $20 \pm 3^\circ\text{C}$ to which not more than 0.5 g/L of a neutral wetting agent has been added. Test each sample in accordance with CAN/CGSB-4.2 No. 32.2-M89.
- 6.1.5 **Ankle, Wrist and Other Strap Attachment Strength** — The attachment strength of ankle and wrist straps shall not be less than 222 N.
- 6.1.5.1 **Attachment Strength Test** — Prepare 10 samples of the strap and fabric combination. Five samples shall have the strap secured to the fabric parallel to the fabric warp yarns and five samples, parallel to the weft yarns. The intended securing means (e.g. Box X stitch) shall be used. The samples shall be clamped between the jaws of a tensile testing machine with the strap in the direction of jaw travel. The jaws are to be separated at a rate of 300 mm/min.
- 6.2 **Temperature Cycling** — The suit system shall show no signs of damage such as shrinking, cracking, swelling, dissolution, or change of mechanical qualities when donned and secured subsequent to the Temperature Cycling Test (par. 6.2.1).
- 6.2.1 **Temperature Cycling Test** — Expose each suit system alternately to temperatures of -30 and 65°C . Hang the suit system and repeat the following procedure for a total of five cycles:
- Expose the suit system at 65°C for 8 h.
 - Remove the suit system from the warm chamber and expose it for a period of not less than 8 h at room temperature.
 - Expose the suit system at -30°C for 8 h.
 - Remove the suit system from the cold chamber and expose it for a period of not less than 8 h at room temperature.
- 6.3 **Materials**
- 6.3.1 **Oil Resistance** — After contact with oil or grease, the suit system shall show no signs of damage such as shrinking, cracking, swelling, dissolution or change of mechanical qualities. The seams shall have a breaking strength of not less than 150 N.
- 6.3.1.1 **Oil Resistance Test** — At least two samples of each type of exterior fabric and each seam type are required for this test. Immerse or coat at least two samples of each type of exterior fabric and seam-type combination and allow them to stand for a period of not less than 6 h in
- marine diesel oil, in accordance with CGSB standard 3-GP-11d (2002) (soak);
 - cod liver oil (soak); and

- c. multipurpose bearing grease, in accordance with CGSB standard 3-GP-691c (1995) (coat).

Note: Each fabric and seam-type sample is only exposed to one contaminant.

- 6.3.1.1.1 Upon completion of the 6 h period, wipe off each sample and test one sample of each type of fabric and seam as described in CAN/CGSB-4.2 No. 9.2-M90 (fabrics) and No. 32.2-M89 (seams).
- 6.3.1.1.2 Test one sample of each type of exterior fabric and seam-type combination in accordance with CAN/CGSB-4.2 No. 26.1-M88, under a 1 m head of water for a period of not less than 1 h.
- 6.3.2 **Corrosion Resistance of Metal Parts** — Each metal part of the suit system shall be
 - a. fabricated from one of the following:
 - i. naval brass in accordance with ASTM B 21/B 21M-01e1; or
 - ii. metal for which there is published evidence of salt-spray corrosion resistance; or
 - iii. metal with corrosion resistance equal to or greater than naval brass when tested in accordance with par. 6.3.2.1; and
 - b. compatible galvanically with any other metals with which it may be in contact, as determined by meeting the requirements of the corrosion resistance test (par. 6.3.2.1).
- 6.3.2.1 **Corrosion Resistance Test** — Test a sample of each metal and metal combination under test and a sample of naval brass for 720 h in accordance with ASTM B 117-03. At the conclusion of the test, each sample of test metal and metal combination shall show corrosion resistance equal to or better than the sample of naval brass.
- 6.3.3 **Fabric** — The exterior fabrics shall meet the requirements of CAN/CGSB-65.19-2004 for Type I or Type IV fabric. The lining shall meet the requirements of CAN/CGSB-65.19-2004 for any fabric type except that the accelerated weathering test is not required.
- 6.3.3.1 Suit system components, such as boots, cuffs, fasteners, gloves, hood seal, hood seal trim, tapes, threads, or webbing, may be of any colour.
- 6.3.3.2 **Fabric Abrasion Resistance** — When tested in accordance with ASTM D 3886-99, the number of cycles to hole formation on the outer surface of the exterior fabric shall exceed 500.
- 6.3.4 **Thread** — The thread shall comply with the requirements of CAN/CGSB-65.19-2004.
- 6.3.5 **Hardware and Fasteners** — All hardware and fasteners shall be of a size and design consistent with the webbing, tape or fabric with which they are engaged. They shall be located to enhance the wearability of the device.
- 6.3.5.1 Hardware shall comply with the requirements of 19.1 to 19.4 of UL 1191-1997.
- 6.3.6 **Zippers** — Zippers shall comply with the following:
 - 6.3.6.1 **Opening and Closing Force Test**
 - 6.3.6.1.1 Conduct opening and closing force tests on four samples of 750 mm long zippers (two open ended and two closed ended) after conditioning in the half-way-open position as follows:
 - a. Test one sample in the as-received condition.
 - b. Test one sample after conditioning for 720 h in a salt spray of 5% sodium chloride in accordance with ASTM B 117-03.
 - c. Test one sample after conditioning for 24 h under a 100 mm head of No. 2 marine diesel oil at a temperature of 18 to 20°C.
 - d. Test one sample after being folded in half lengthwise to form a radius of not more than 25 mm and subjected to the Temperature Cycling Test (par. 6.2.1).
 - 6.3.6.1.2 Conduct the opening and closing force tests on completion of the final cold exposure with the samples maintained at -30°C. Conduct the opening test described in ASTM D 2062-87(1997)e1, 16, on the samples conditioned in the closed position. Conduct the closing test described in ASTM D 2062-87(1997)e1, 16, on samples conditioned in the open position.

- 6.3.6.1.3 The test results shall not exceed
- 40 N opening and closing force after conditioning as described in par. 6.3.6.1.1 a., except docking at the top stop shall be 50 N;
 - 60 N opening and closing force after conditioning as described in par. 6.3.6.1.1 d.; and
 - 175 N opening and closing force after conditioning as described in par. 6.3.6.1.1 b. and c.
- 6.3.6.2 *Point Breaking Strength Test* — On completion of the opening and closing tests, subject all samples to this test at the top, bottom end, and centre (at the point of folding as described in par. 6.3.6.1.1 d.). Test the point breaking strength as described in UL 1191-1997. The point breaking strength (averaged results) shall not be less than 440 N.
- 6.3.6.3 *Diagonal Pull Test*
- 6.3.6.3.1 Prepare three 750 mm long zipper samples as follows:
- one sample in the as-received condition;
 - one sample after conditioning as described under par. 6.3.6.1.1 b.; and
 - one sample after conditioning as described under par. 6.3.6.1.1 c.
- 6.3.6.3.2 Open and mount the samples securely onto a hard flat surface such as a wood board, as follows:
- one of each sample as in par. 6.3.6.3.1, secured with the left side of the zipper secured.
 - one of each sample as in par. 6.3.6.3.1, secured with the right side of the zipper secured.
- 6.3.6.3.3 Close zippers secured on the left side by pulling the slider at an angle of approximately 25° to the right of the line of the zipper (Figure 2a.). Close zippers secured on their right side by pulling the slider at an angle of approximately 25° to the left of the line of the zipper (Figure 2 b.). Pull the unsecured part of the closed zipper at an angle of 90° to the line of the zipper, away from the secured part with a force of not less than 45 N (Figure 3). The zipper points shall not pull free.
- Note: The procedures described in par. 6.3.6.3.2 and 6.3.6.3.3 apply to asymmetrical zippers only. Symmetrical zippers shall be tested on either the left or the right side.*
- 6.3.6.4 *Leak Resistance Test*
- 6.3.6.4.1 Prepare two 305 mm long zippers by gluing and securing to a 356 mm long piece of 5 mm thick nylon-both-sides neoprene to form a 127 mm diameter cylinder. Seal the bottom end of the cylinder with another piece of 5 mm nylon-both-sides neoprene.
- Note: It is recommended that the insides of the glued seams be checked for their tightness as these samples will be used for the leak test, and the adhesive used shall be resistant to diesel oil, as these samples will be tested for their resistance to diesel oil.*
- 6.3.6.4.2 Place a wire mesh fixture 300 mm in length and 125 mm in diameter inside the sample, and close the zipper fully. Place the sample in a water tank with the closed end of the sample down to a depth sufficient to submerge 90% of the zipper's effective length (the portion measured from the top of the bottom stop to the bottom of the slide when the slide is in the fully closed position). Then remove the sample from the water and blot the inside with pre-weighed blotting paper to absorb any water that ingressed. The mass of the ingressed water shall not exceed 20 g.
- Note: The acceptable value will be established based on the volume of the sample compared to the volume of a typical adult "Universal" size suit system.*
- 6.3.6.4.3 Next, allow the sample to dry and then place it in No. 2 marine diesel oil at a depth as prescribed in par. 6.3.6.4.2 for a period of 24 h. Remove the sample, blot it dry, and repeat the test described in par. 6.3.6.4.2. The zipper will be considered acceptable if the amount of water that ingressed is minimal, and there is no sign of degradation resulting from its exposure to the diesel oil.

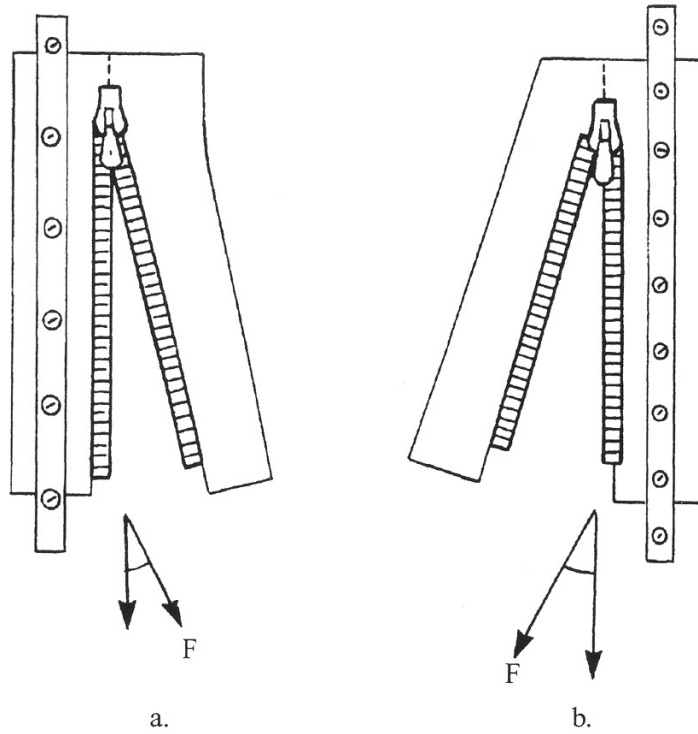

FIGURE 2
Asymmetrical Zipper Closure

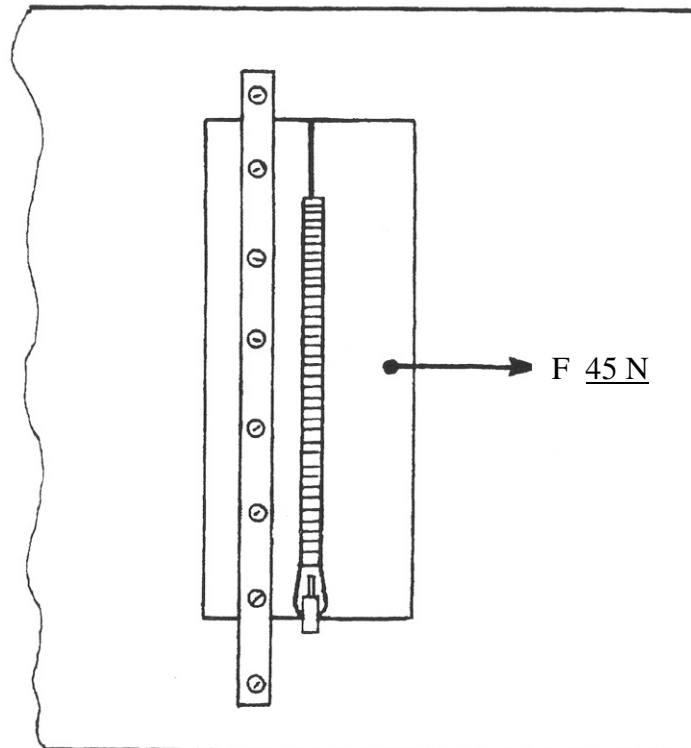

FIGURE 3
Closed Zipper Assembly

- 6.3.7 **Retroreflective Material** — The retroreflective material shall conform to the specification detailed in Resolution A.658(16) with an area of at least 300 cm² on the front and with at least 100 cm² on the back. Retroreflective material shall be placed on the suit system to cover a minimum surface area of 200 cm² above the water level when tested with the subject in a relaxed, floating position.
- 6.4 **Inherent Buoyancy (Static)**
- 6.4.1 The suit system shall provide a minimum inherent buoyancy of not less than 70 N.
- 6.4.2 **Inherently Buoyant Materials** — Inherently buoyant materials shall be unicellular foam conforming to CAN/CGSB-65.18-M86. Kapok or other natural fibre shall not be used as a buoyancy medium.
- 6.5 **Buoyancy** — The original buoyancy, the buoyancy after 24 h immersion, the buoyancy retention, and the corrected buoyancy of the suit system shall be measured as follows:
- 6.5.1 **Test Equipment** — The following equipment is required for this test:
- A mesh basket that is large enough to hold a folded suit system and that is weighted sufficiently to overcome the buoyancy of the suit system when placed in the basket.
 - A tank of fresh water that is large enough to contain the basket submerged with its top edge 50 mm below the surface of the water.
 - A scale or load cell with an accuracy of ± 1 g and that is arranged to support and determine the mass of the basket in the tank.
 - One complete, unassembled suit system.
- 6.5.2 **Determination of Original Measured Buoyancy** — Submerge the basket so that its top edge is 50 mm below the surface of the water. Determine the mass of the submerged basket. Thereafter, submerge the suit system in the water, ensuring it is filled with water and any inflation elements are fully deflated; then place it in the submerged basket. Tilt the basket 45° from the vertical for 5 min in each of four different directions to allow entrapped air to escape. Suspend the basket with the suit system in the water with the top edge of the basket 50 mm below the surface of the water. Determine the mass of the submerged basket and the suit system immediately. Determine the original measured buoyancy of the suit system by subtracting the mass of the basket plus the suit system from the mass of the basket. Calculate the buoyancy in Newtons (N). The suit system can be a fully assembled suit or all the unassembled components.
- 6.5.3 **Determination of Buoyancy After 24 h Immersion** — Submerge the suit system in the tank of fresh water for 24 h. Determine the buoyancy as described in par. 6.5.2.
- 6.5.4 **Buoyancy Retention** — Calculate the buoyancy of the suit system after 24 h immersion (par. 6.5.3) and express it as a percentage of the original measured buoyancy (par. 6.5.2).
- 6.5.5 **Corrected Inherent Buoyancy** — The corrected buoyancy of the suit system is its measured buoyancy reduced by the buoyant correction factor of the buoyant suit system material. The correction is made for barometric pressure and water temperature and is determined in accordance with UL 1191-1997 except that the minimum number of samples required to determine each property shall be 10 instead of 75.
- 6.5.5.1 Calculate the corrected inherent buoyancy as follows:
- $$B_C = B_M \times (P / 760) \times (527.69 / T_M)$$
- where:
- B_C = Corrected buoyancy, in newtons
 B_M = Measured buoyancy, in newtons
 P = Atmospheric pressure, in millimetres of mercury
 T_M = Temperature, in degrees Rankine
- 6.5.6 **Determination of Corrected Buoyancy After 24 h Immersion** — Determine the buoyancy of the suit system after 24 h immersion in accordance with par. 6.5.2, and correct this buoyancy value in accordance with par. 6.5.5.

6.5.7 **Buoyancy Loss**

6.5.7.1 The minimum design buoyancy of the suit system shall be calculated in accordance with the following formulae depending on the buoyant material so that the predicted minimum buoyancy is not less than the total buoyancy requirement (par. 6.4.1).

- a. Buoyant neoprene materials — Shall be calculated in accordance with the formula outlined in UL 1197-1996, 23.7.
- b. Other buoyant polymeric materials — Shall be calculated in accordance with the following formula¹:

$$B_i = B_t \times \sum_{i=1}^n (P_i \times 100) / V_i$$

where:

B_i = Minimum production buoyancy for the suit system, in newtons

B_t = Minimum total buoyancy required for the suit system, in newtons

P_i = Percentage of buoyancy provided by the *i* th material to the total buoyancy of the suit system

n = Number of materials used in the suit system

V_i = V-factor of the *i* th buoyant material

6.5.7.2 The V-Factor for any buoyant material necessary to meet these requirements shall not be less than 85 when tested in accordance with CAN/CGSB-65.18-M86 or UL1123-1996, 24.4.

6.5.7.3 **Exception In The Equation Including Subscripts** — Foam that is used may have a V-factor not less than 80 provided that at least 85% of the total minimum buoyancy is supplied by foam with a V-factor of 85 or more. Foam that is not relied upon to meet the requirements for total minimum buoyancy shall be excluded from this V-factor requirement provided the suit system complies with the flotation stability requirements (par. 6.20) with such buoyant materials in place.

For non-polymeric materials, the buoyancy after 24 h submersion in water shall be determined in accordance with par. 6.5.2.

Note: Additional buoyancy elements are excluded from this requirement.

6.5.8 **Total Buoyancy** — Auxiliary buoyancy may be added to the minimum inherent buoyancy (par. 6.4.1). After 45 s upon water entry, the total buoyancy shall not be less than 150 N. Determine the total buoyancy in accordance with par. 6.5.

6.5.9 **Auxiliary Buoyancy in the Equation Including Subscripts** — If an auxiliary buoyancy element is required, it shall be attached to the suit system in a manner that prevents removal by the wearer.

6.5.9.1 Inflation chambers, required to meet the minimum total buoyancy, shall meet the following requirements of UL 1180-2004:

- a. 7.9 — Strength of Attachment Tests
- b. 7.10 — Temperature Resistance/Stability Test
- c. 7.11 — Solvent Resistance Test
- d. 7.12 — Flame Resistance Test
- e. 7.14 — Puncture Resistance Test
- f. 7.15 — Over-Pressure Tests, and
- g. 7.16 — Air Retention Test.

6.5.9.2 If the inflatable buoyancy element is totally enclosed within the shell of the suit system, then the tests shown in par. 6.5.9.1 a. and d. shall be performed on the complete assembly.

¹ This formula establishes the absolute minimum production buoyancy and does not address manufacturing tolerances.

- 6.5.9.3 If inflation is achieved entirely by oral inflation, then the test shown in par. 6.5.9.1 f. is not required.
- 6.6 **Flame Resistance** — The suit system and the storage container (if required) shall be designed to be functional after a 2 s contact with a gasoline fire.
- 6.6.1 **Flame Resistance Test** — The suit system and storage container shall be tested for resistance to flame as follows:
- 6.6.1.1 **Test Equipment** — The following equipment is required for this test:
- A metal pan at least 300 mm wide, 450 mm long, and 65 mm deep. The pan shall have at least 12 mm of water on the bottom with approximately 40 mm of gasoline floating on top of the water.
 - An arrangement to hold the suit system and storage container over the pan.
- 6.6.1.2 **Flame Exposure Test Procedure** — The suit system is held from the top by the holding arrangement. Ignite the gasoline and allow it to burn for approximately 30 s in a draft-free location. The suit system is then held with the lowest part of each foot 240 mm above the surface of the burning gasoline. After 2 s, measured from the moment the flame first contacts the suit system, remove the suit system from the fire. If the suit system is burning, allow it to continue to burn for 6 s before extinguishing the flames. If the suit system sustains any visible damage other than scorching, subject it to the flotation stability requirement (par. 6.20) using one subject and to the Buoyancy Test (par. 6.5) except the immersion time shall be for 2 h instead of 24 h.
- 6.6.1.3 **Storage Container Flame Exposure Test Procedure** — Test the storage container using the test equipment. Place the suit system inside the storage container for the test. The storage container is held from the top by the holding arrangement. Ignite the gasoline and allow it to burn freely for approximately 30 s in a draft-free location. The storage container is then held with its lowest point 240 mm above the surface of the burning gasoline. After 2 s, measured from the moment the flames first contact the container, remove the container from the fire. If the container is burning, allow it to continue to burn for 6 s before extinguishing the flames. The storage container material shall not burn through at any point in this test, and the suit system shall not sustain any visible damage.
- 6.7 **Human Testing**
- 6.7.1 **General** — Each adult and child size suit system shall be tested. CAUTION: During each in-water test, a person ready to render assistance when needed should be near each subject in the water.
- 6.7.2 **Test Anomalies** — Throughout the testing program, certain results may vary significantly from the collected data set. Such results must be recognized and validated by the testing agency. Where this variation is determined to be a suit system design or performance factor, the results shall remain as part of the data set. Where this variation is determined to be an anomaly caused by subject activities, which are outside the scope of the specific test objective, the test may be repeated or the results deleted from the data set.
- 6.7.3 **Testing For Child Size Suit Systems** — Child-size suit systems shall pass the following tests:
- The flotation stability requirement (par. 6.20) except that six children of either sex shall be used as subjects. The subjects shall be within the size prescribed in Table 1 (par. 4.1.2.1), and have a mass spread of at least 4 kg between subjects.
 - The Buoyancy Test (par. 6.5)
 - Body Strength (par. 6.1.1) except that the cylinders shall be 50 mm in diameter and the test mass shall be 55 kg.
- 6.7.4 **Test Clothing** — Clothing to be worn for each test procedure shall consist of
- underwear (short sleeved, short legged),
 - shirt (long sleeved),
 - trousers (not woollen), and
 - wool socks.

- 6.8 **Donning Time** — Following a demonstration, each subject shall be able to unpack, don and secure the suit system over his or her test clothing unassisted and within 2 min. Where the suit system is intended to be used for helicopter transit flights and is designed to be worn unsealed in flight, it shall be capable of being correctly sealed by the wearer within 10 s. This action shall be possible when seated at the wearer's normal position in a helicopter with harness fastened and wearing an uninflated life jacket, if required.
- 6.8.1 **Donning Time Test** — Test the donning, mobility and flotation capabilities of each suit system as follows. The depth of water shall be at least 3 m.
- 6.8.1.1 **Test Subjects** — Each test shall be performed using as many samples of the suit system as are needed to make efficient use of the subjects and test equipment. If the exterior fabric is a composite fabric, it shall be tested as a composite fabric unless otherwise stated. There shall be seven male and four female subjects. The subjects shall be comfortable in the water and shall be selected to represent the body height and mass ranges, as specified in Table 3.

TABLE 3
Test Subject Sizes

Body Height cm	Body Mass kg
140 to 160	Under 60
140 to 160	Over 60
160 to 180	Under 70
160 to 180	Over 70
Over 180	Under 80
Over 180	Over 80

- 6.8.1.1.1 At least two of the eleven subjects shall have a chest size of 760 ± 25 mm. At least two of the eleven subjects shall have a chest range of 1320 ± 25 mm.
- 6.8.1.1.2 In the event that a size of suit system is not accommodated by the above selection of subjects, an additional subject shall be used to ensure all sizes are tested.
- 6.8.1.2 **Donning Time Test Procedure** — If the suit system under test is designed to be worn with rubber boots, then standard fishermen's rubber boots shall be worn for the test. Each subject shall be removed from the view of the other subjects and allowed 10 min to examine the suit system and the manufacturer's instructions for donning and using the suit system. The subject shall then attempt to don the suit system as rapidly as possible without the aid of a chair or any support on which to lean. The subject, however, may sit on the floor. Each subject shall don the suit system completely, in a single attempt and within 2 min.
- 6.9 **Cold Donning Time** — The suit system, immediately after exposure in the packed condition for 24 h at -30°C , shall be capable of being donned in less than 5 min.
- 6.9.1 **Cold Donning Time Test Procedure** — Repeat the Donning Time Test procedure (par. 6.8.1.2) except the time period is 5 min and the ambient room temperature is -30°C .
- 6.10 **Donning Durability** — The suit system shall be donned and doffed ten times without sustaining damage.
- 6.11 **Mobility** — The suit system shall permit the wearer to climb, bend, move arms, and walk without restriction.
- 6.11.1 **Mobility Tests** — Mobility shall be tested according to the following tests:

- 6.11.1.1 **Mobility Out of the Water Test** — The suit system shall be completely donned and any zippers or ties that would normally be closed under working conditions shall be fastened. The following tests shall then be conducted to test the mobility of the suit system:
- a. Each subject shall assume the squatting position with no difficulty or discomfort.
 - b. Each subject shall assume the sitting position with no difficulty or discomfort.
 - c. With the arms by the side fully extended, each hand grasping a 1 kg dumbbell, and the knuckles facing the sides of the thighs, each subject, with no difficulty or discomfort, shall be able to raise the arms through a full arc above the head until the arms are fully extended and the flexed fingers touching above the head.
 - d. Starting from the same position as in par. 6.11.1.1 c., each subject with arms fully extended shall be able to raise the arms laterally to 90° without difficulty or discomfort. Then, with the arms fully extended and parallel to the ground, each subject shall be able to rotate them in front until the flexed fingers of the hands holding the dumbbells touch.
 - e. A vertical ladder extending at least 5 m above a level floor shall be used for the last part of the test. Each subject while not wearing the suit system is timed twice climbing the ladder so that feet are at a height of 3 m above the floor. The subject shall then don the suit system and is again timed twice climbing to the same height. The average time for each subject wearing the suit system to climb the ladder shall not exceed the average time for each subject not wearing the suit system to climb the ladder by more than 10%.
- 6.11.1.2 **Mobility in the Water Test** — Mobility in the water shall be tested as follows:
- a. The life raft used for this test shall be a nonreversible, dual chamber, 10-man capacity life raft with a boarding ladder. The raft shall be free-floating in water at a temperature of not less than 18°C. A brief demonstration on how to right an inverted life raft shall be given to the subjects. Each subject, wearing only test clothing, shall enter the water, and swim or tread water for approximately 2 min. The subject shall then be able to right the life raft and climb into it via the boarding ladder with no other boarding aids in a maximum of 3 min. Only subjects that can perform this task shall be used in the subsequent test. A minimum of eight subjects, of which two shall be female, must qualify.
 - b. The test is then carried out with the qualifying subjects as follows:
 - i. Each subject shall don the suit system over their test clothing, enter the water, and deploy the auxiliary buoyancy element. The subject is allowed to adjust any buckles, fittings, etc. The subject shall then swim 25 m. The time required to swim 25 m with the suit system and test clothing on shall not exceed the time required to swim 25 m with only the test clothing on by more than 25%.
 - ii. The subject is then required to right an inverted life raft and climb into the life raft via the boarding ladder, with no other boarding aids, in a maximum of 6 min. All qualifying subjects shall pass the test.
- 6.12 **Hand Dexterity** — While wearing the suit system, each test subject shall be capable of performing all of the following hand tests.
- 6.12.1 **Hand Dexterity Test** — If gloves are fitted to or provided with the suit system, then each subject shall pass the following tests while wearing the gloves:
- a. At any time, pick up a pencil of 10 mm in diameter and write.
 - b. Cut a painter using a standard raft knife² within 1 min.
 - c. Unroll five turns of 2 cm black plastic insulating tape from a 4 cm dowel to simulate preparing a hand flare for use. (The first 2 cm of tape shall be folded back on itself to form a 1 cm starter tab simulating a tab on a flare.)
- 6.13 **Swimming** — The suit system, fully deployed, shall permit the subject to swim through the water at least 25 m and board a survival craft in accordance with par. 6.11.1.2 b.
- 6.14 **Leakage** — The ingress of water into the suit system shall be measured in accordance with par. 6.22.1.1.
- 6.15 **Skid Resistance** — Each subject, wearing only the test clothing (par. 6.7.4) and rubber-soled shoes, shall walk a distance of 30 m on a smooth, wet surface such as tile or painted concrete. The smooth, wet surface shall be 23 ± 5°C. There shall be at least one turn of at least 90° in the 30 m course. The course shall be walked twice,

² The painter and standard raft knife are provided with the life raft described in par. 6.11.1.2 a.

and the times recorded. The walk is repeated and timed with the suit system fully donned. The average time while wearing the fully donned suit system shall not exceed by more than 25% the average time recorded when not wearing the suit system.

- 6.16 **Jump** — The suit system shall permit the wearer to jump from a height of not less than 4.5 m into the water with feet first, without damaging or dislodging the suit system or being injured.
- 6.16.1 **Jump Test** — The subject shall jump into the water feet first from a height of 4.5 m. After water entry, the subject may make initial in-water adjustments to the suit system to improve his or her field of vision and breathing. However, if this cannot be accomplished within 1 min of water entry, the suit system shall fail this test. After the initial in-water adjustments, the subject shall assume a relaxed, floating position in the water for 10 min with the arms at the sides, making no conscious effort to prevent the suit system from riding up. After removal from the water, measure the ingress of water into the suit system in accordance with par. 6.22.1.1.
- 6.17 **Head-First Entry** — The subject, while wearing the suit system, shall enter the water head first from a height of 1 m above the water surface and shall attain a head-up floating position within 5 s of water entry.
- 6.18 **Field of Vision** — The suit system shall comply with the following field of vision requirements on land and in water.
- 6.18.1 **Field of Vision on Land** — With the subject in a seated position, head perpendicular to the shoulder plane, suit system fully secured and the inflatable buoyancy element, if any, uninflated, the average single field of lateral vision must be at least 120°. With the subject's head rotated 30° to the left of the perpendicular of the shoulder plane and then 30° to the right, the average single field of lateral vision must also be at least 120°.
- 6.18.2 **Field of Vision in the Water** — With the subject floating in a relaxed position in the water with the suit system fully secured and the inflatable buoyancy element, if any, fully inflated, the subject's field of vision shall be
- lateral, unrestricted 120° arc of vision from left to right, water level to water level;
 - vertical, forward through an arc of 60° and backward through an arc of 15°; and
 - horizontal, an arc of 30° starting at right angles to the body and sweeping down towards the feet, parallel to the water surface.
- 6.18.3 **Field of Vision Tests** — The suit system's field of vision shall be tested as follows:
- 6.18.3.1 **Field of Vision on Land Test** — Each subject, not wearing a suit system, shall be seated with the chin resting firmly on a support and shall look straight ahead. A person carrying a lighted flashlight pointed at the subject's head shall stand behind the seated subject and walk clockwise and then counter clockwise around the circumference of a circle with a 5 m radius, of which the seated subject's head is at the centre. It shall be established from the results of carrying out this test that the seated subject, moving the eyes if necessary, can observe the lighted flashlight on each side at an angle of at least 60° from the perpendicular of the shoulder plane. The test shall then be repeated with each subject having fully donned the suit system with the auxiliary buoyancy element, if any, uninflated for each of the following positions:
- head perpendicular to the shoulder plane;
 - head rotated 30° to the left of the perpendicular of the shoulder plane; and
 - head rotated 30° to the right of the perpendicular of the shoulder plane.
- 6.18.3.2 **Field of Vision in Water Test** — The field of vision shall be measured in the lateral, vertical and horizontal planes with the suit system fully donned and auxiliary buoyancy element, if any, fully inflated. The Bohemier Perimeter Scope³ (Figure 4) or equivalent shall be used to measure field of vision. Measure the field of vision of each subject in the relaxed flotation position with the head fixed and eyes allowed to move, in the lateral (Figure 5a), horizontal (Figure 5b) and vertical (Figure 5c) planes.

³ This device has studs to stabilize the subject's head and a 2 cm plastic pipe bent into a semicircle measuring 2 m in diameter. Marks are placed on the ring at 15 cm intervals using a selection of coloured tapes.



FIGURE 4

Bohemier Perimeter Scope

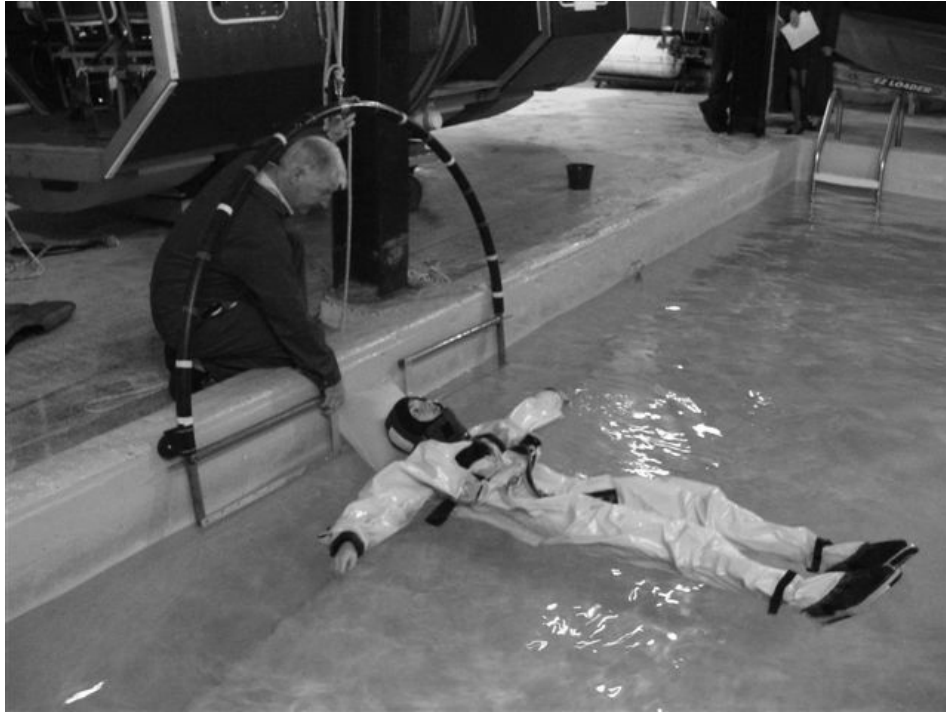

FIGURE 5a

Field of Vision in the Water — Lateral Plane



FIGURE 5b

Field of Vision in the Water — Horizontal Plane



FIGURE 5c (i)

Field of Vision in the Water — Vertical Plane Forward

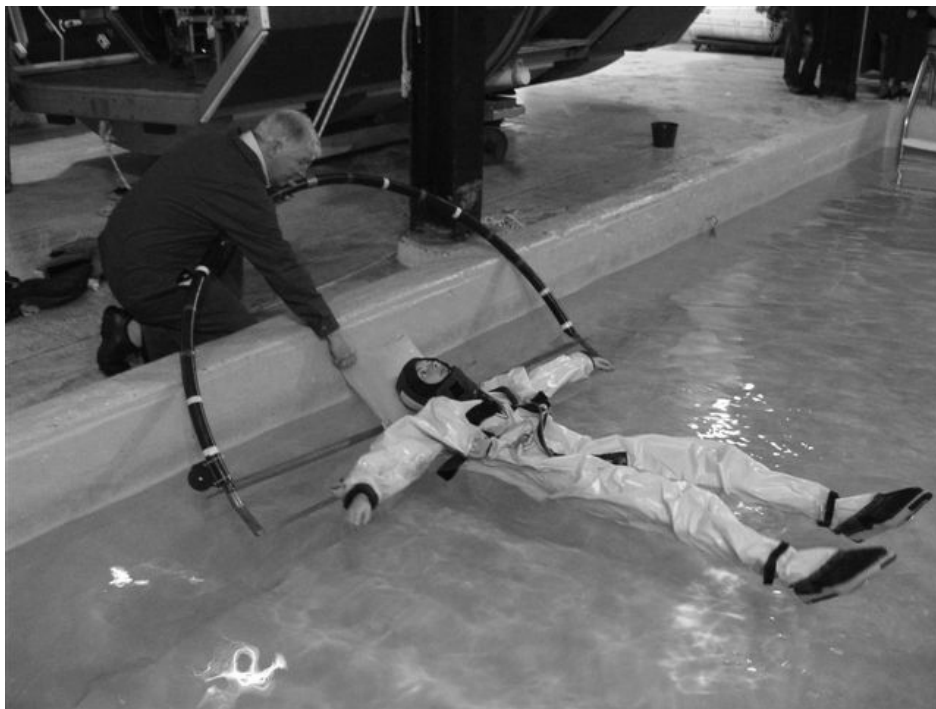

FIGURE 5c (ii)

Field of Vision in the Water — Vertical Plane Backwards

- 6.19 **Retroreflective Tape** — Each subject, wearing the suit system fully deployed, shall adopt a relaxed, floating position in the water. The surface area of the retroreflective tape above the water level is then measured. Measurements on at least 9 out of 11 subjects shall meet the requirement, and no measurement shall be below 75% of the requirement.

6.20 **Flotation Stability**

6.20.1 **Righting** — While wearing the suit system in the water fully secured with any inflatable buoyancy element inflated, each subject shall take a deep breath, assume a facedown position, allow the body to become limp, and slowly expel air. The suit system shall cause the subject to turn face-up within 5 s. If the suit system does not turn the subject within 5 s, the subject shall be able to turn face-up under his or her own power within 5 s. The suit system shall not have the tendency to turn a subject facedown from a face-up position.

6.20.2 **Freeboard**

6.20.2.1 Each subject, in turn, while wearing the suit system correctly secured and adjusted, shall step from a platform located not less than 4.5 m above the water.

6.20.2.2 The suit system shall position the wearer's mouth above the water surface within 5 s of water entry.

6.20.2.3 The suit system shall allow the subject to attain a near vertical position with a minimum freeboard of 120 mm within 15 s of water entry.

6.20.2.4 The subject shall be permitted to make any adjustments and deploy any auxiliary buoyancy element within 45 s of water entry. At this point in time, the suit system shall provide a minimum buoyancy of 150 N and a minimum relaxed freeboard of 120 mm. On completion of the relaxed freeboard measurements, the suit system is removed from three of the subjects (one large, one medium, and one small), and the total buoyancy of each is measured immediately (par. 6.20.4).

6.20.2.5 **Face-plane** — The suit system shall support each subject in a relaxed, stable, face-up position with a face-plane angle of 30 to 80° above the horizontal.

6.20.2.6 **Stability in the Water** — With the suit system deployed, each subject shall be able to maintain a vertical position for 2 min without assistance or undue effort.

6.20.3 **Inherent Buoyancy Freeboard Test** — The subject shall don the suit system, and secure and adjust any fasteners. The auxiliary buoyancy element, if any, shall not be deployed. The subject shall adopt a squatting position and place two fingers under the neck or face seal for 5 s to allow entrapped air to escape. The subject is then to enter the water and adopt a relaxed position. Measure the freeboard at the lowest point of the breathing cycle. Freeboard shall not be less than 50 mm. Measurements on nine out of eleven subjects shall meet the requirement, and no individual measurement shall be below 41 mm.

6.20.4 **Total Buoyancy Test** — Forty-five seconds after water entry, three of the subjects shall remove the suit system while in the water. The suit system shall support a weight assembly having an in-water mass of 15.3 kg.

6.21 **Sprayhood** — If any form of hood or sprayhood is fitted to cover the face in whole or in part (to protect mouth and nose from water splash), the carbon dioxide level within the hood shall not exceed 5% at any time and does not average more than 2.5% in any one minute.

The sprayhood shall be stowed in a position that keeps it clear of the user's face. It shall not interfere with the operation of a lifejacket (if fitted as part of the immersion suit system) or create a hazard, for example through snagging.

The sprayhood shall be able to be un-stowed and deployed to protect the airway whilst the user is in the water. If a lifejacket is deployed as part of the immersion suit system, the sprayhood shall not impair the performance of the suit system and render it no longer in conformity with the relevant standards.

The sprayhood shall be fitted with a clear area to enable the user to see sufficient of the surroundings in order to aid rescue operations. If, when deployed, the sprayhood reduces the effectiveness of any retroreflective material on the immersion suit system, the sprayhood shall itself provide additional retroreflective area at least equal to that obscured. The sprayhood shall be easily removable from its protective position, and shall be capable of being restored so that it does not fall back to its deployed position.

6.21.1 **Apparatus** — A fast-response carbon dioxide analyser, capable of indicating continuous measurements of the percentage of carbon dioxide gas within a continuously flowing sample, with a time constant short enough to give accurate measures of end-tidal carbon dioxide level.

6.21.2 **Procedure** — Demonstrate, by analysing samples of gas using a fast-response carbon dioxide analyser, that in calm air and calm water, using a minimum of six subjects over test periods of at least 5 min each, that the carbon dioxide level within the hood does not exceed 5% at any place at any time and does not average more than 2.5% in any 1 min.

Take the samples at a distance between 50 mm and 100 mm from the nostrils, when the subject is holding breath. The longest averaging period shall not exceed 60 s.

6.22 **Thermal Performance** — Thermal performance parameters are established and measured as follows for thermal manikins and human subjects.

6.22.1 **Using Thermal Manikin** — The mean level of thermal insulation over the body as provided by the suit system, including test clothing, shall not be less than $0.116^{\circ}\text{C}\cdot\text{m}^2\cdot\text{W}^{-1}$ (0.75 immersed Clo). The hands shall have a minimum thermal protection value of $0.6\text{ K}\cdot\text{m}^2\cdot\text{W}^{-1}$ (0.5 immersed Clo).

6.22.1.1 **Determination of Water Ingress** — The amount of water ingress is required so that it may be introduced into the suit system (dry suit systems only) prior to testing using a thermal manikin and human subjects. The subjects shall be as described in Table 3 (par. 6.8.1.1). Prior to testing, determine the saturation time of the suit system material by conducting a series of tests using two subjects, following the test procedures described in par. 6.22.1.1.1 and 6.22.1.1.2, increasing the saturation time by 2 min for each test until the saturation mass does not show a significant increase. That time shall be the established saturation time for this test.

6.22.1.1.1 **Water Ingress During Jump Into Water** — Each subject, with the suit system fully donned and detachable components, if any, removed (e.g. hood, gloves, buoyancy element) shall climb into the water and remain in the vertical position with the water at neck level for the established saturation time to pre-wet the suit system. Each subject shall then climb out, dunk his/her head in water up to the neck to soak the hair, stand for 1 min to permit excess water to run off the exterior of the suit system, and shall then be weighed. Means shall be provided so that any further run-off is included in the weighing. Observe and record the amounts and locations of any water leakage into the suit.

Each subject, with the suit system fully donned including detachable components, shall then jump into the water from a height of not less than 3 m to ensure total immersion. The jump shall be carried out in a feet first position and with feet together. Arms should be crossed over the chest using one hand to protect the nose and mouth. The subject shall then remain still in the water for at least 1 min before being manoeuvred into a position at the pool side where it is possible to climb out with a minimum of effort. Immediately after the subject has left the water, detachable components shall be removed. The subject shall stand for 1 min to permit excess water to run off the exterior of the suit system and then be weighed again in that any further run-off is included in the weighing. The weighing machine shall be capable of measuring 250 kg with an accuracy of ± 0.025 kg.

On completion of the test, each suit system shall be removed and a record made of the location of any leaks and damp patches observed as well as the total mass of water leaked into the suit system.

6.22.1.1.2 **Water Ingress During Swimming** — The test shall take place in a swimming pool with a water temperature of not less than 18°C . Each subject, with the suit system fully donned and all detachable components, if any, removed (e.g. hood, gloves, buoyancy element), shall climb into the water and remain in the vertical position with the water at neck level for the established saturation time to pre-wet the suit system. Each subject shall then climb out, stand for 1 min to permit excess water to run off the suit system and shall then be weighed again in order that any further run-off is included in the weighing.

A minimum of three subjects shall participate in the test together in order to achieve adequate wave motion in the pool. At the start of the test, each subject, with the suit system fully donned including detachable components, shall enter the water via a stepladder and proceed to swim on his/her back and abreast, with a maximum distance of 2 m between subjects and at an approximate speed of 18 m/min for 60 min. Subjects shall use their arms and legs for swimming throughout. The distance covered shall be recorded and must lie between 1000 and 1200 m. Each subject shall then leave the water and remove the detachable components immediately. Each subject shall stand for 1 min to permit excess water to run off the suit system. The suit system is then weighed.

6.22.1.1.3 Calculation of Water Ingress — Calculate the amount of water, W , to be introduced at the start of the insulation measurement using the formula

$$W = W_1 + 3 L$$

where:

W = mass of water to be introduced, in grams

W_1 = water ingress, in grams, average for eleven subjects, measured at jump test

L = water ingress, in grams, average for eleven subjects, measured at 60 min swim test.

Note: W_1 and L should be taken as one standard deviation above the mean for the eleven subjects tested.

Where water ingress has been recorded specific to each detachable component, the greatest ingress value recorded from the tests described in par. 6.22.1.1.1 or 6.22.1.1.2 shall be introduced specific to the component it was recorded from.

6.22.1.2 Using Thermal Manikin Test

6.22.1.2.1 The thermal protection provided by the suit system shall be assessed by measuring the effective insulation of the whole suit system and test clothing placed on a thermal manikin and immersed in turbulent water with a wave height of 40 cm with the thermal manikin in a natural floating position as determined in par. 6.22.1.2.3.

6.22.1.2.2 Test Equipment — A thermal manikin is required, and it shall

- a. have a surface area and shape similar to that of a fiftieth percentile man;
- b. be capable of being dressed in the test clothing;
- c. be capable of being heated to, and controlled at, uniform temperature;
- d. control, measure, and record temperatures and power inputs; and
- e. be capable of being immersed in water.

6.22.1.2.3 Flotation Position — A subject of approximately the same mass and height of the manikin and wearing test clothing shall don the suit system, inflate auxiliary buoyancy elements (if any) and enter the calm water. The subject shall assume a relaxed, floating position. The freeboard is measured to the mouth, abdomen and toes, perpendicularly from the surface of the water. This shall be the freeboard and body position used for the thermal manikin.

6.22.1.2.4 Test Procedure — Pre-weigh the test clothing and suit system lining, if any. Dress the thermal manikin in the test clothing and suit system. Inflate auxiliary buoyancy elements, if any. Before closing the suit system closures, introduce water into the test clothing (dry suit system only) in areas representative of those recorded during the water ingress tests and in amounts, W , calculated from the results of the water ingress tests in par. 6.22.1.1.

After closing the suit system closures, ensuring that all seals are closed and waterproof, lower the thermal manikin into the water until the freeboard to the mouth, abdomen and toes equals the amounts measured in par. 6.22.1.2.3. This position may be achieved by mounting the thermal manikin on a support frame.

The target temperature of the thermal manikin and the water temperature are set at levels appropriate to the particular thermal manikin in use. However, the minimum gradient shall not be less than 3°C between the thermal manikin and the water. Provision shall be made for inducing turbulence in the vicinity of the thermal manikin. The temperature(s) of the thermal manikin, the water and the power input(s) shall be measured continuously and recorded as means for each successive period not to exceed 15 min. Once the target temperature is achieved, the thermal manikin shall remain immersed for the time period determined by Defence Research and Development Canada⁴ calibration acceptance testing. This ensures reliable data and consistent test results. Insulation is calculated, in the case of a single section thermal manikin, from the measured temperature gradient, the power input (i.e., heat loss) and the surface area of the thermal manikin. In the case of a thermal manikin consisting of multiple sections, the mean overall insulation is calculated by area, weighting the insulation found in each section. After the thermal manikin is removed from the water, the test clothing and lining shall be reweighed to determine if there was leakage during the test. If leakage has occurred, the measurement of insulation will be lower than it should be and the test may have to be repeated.

⁴ Defence Research and Development Canada (Toronto) can be contacted at 1133 Sheppard Avenue West, Downsview, Ontario, Canada M3M 3B9.

- 6.22.2 **Using Human Subjects** — The suit system shall provide thermal protection such that the average body core (rectal) temperature of persons wearing the suit system for 6 h in calm circulating water that is between 0 and 2°C shall not drop more than 2°C, and the finger, toe or buttock temperature of the wearer shall never drop below 10°C for more than 15 min throughout the entire duration of immersion. Providing the suit system protecting the hands and feet (i.e., gloves and socks) meets a minimum requirement of 0.5 immersed Clo, it is permissible for the testing agency to provide additional insulation to the hands and feet, to prevent the occurrence of non-freezing cold injury in the subjects through hand and foot temperature reductions below these limits. The clo value of gloves can be measured according to the par. 6.22.3.
- 6.22.2.1 **Using Human Subjects Test** — The thermal protection capability of a suit system shall be tested as follows:
- 6.22.2.1.1 **Test Subjects** — At least four male and four female subjects shall be used for this test. Each subject shall be familiarized with the test procedure prior to the start of the test. Each subject must be between 160 and 185 cm tall and must not be more than 10% overweight or underweight for his or her height and physical type as determined by a physician or physiologist or from published physiological data. Each subject shall have had a normal night's sleep the night before the test, a well-balanced meal 1 to 5 h before the test, and no alcoholic beverages for 24 h prior to the test. Each subject shall wear the test clothing in addition to the suit system.
- 6.22.2.1.2 **Test Equipment** — The test shall be conducted in calm circulating water of a temperature between 0 and 2°C. The air temperature 300 mm above the water surface shall be between 10 and 20°C. Each subject shall be instrumented with an electrocardiograph, a thermistor or thermocouple in the rectum placed 150 mm beyond the anal margin, a thermistor or the thermocouple on the tip of the index finger, and a thermistor or thermocouple on the tip of the great toe. Each thermistor or thermocouple shall have an accuracy of 0.1°C.
- 6.22.2.1.3 **Test Procedure** — A physician shall be present during the test. Before donning the suit system, each subject shall rest quietly in a room of temperature between 10 and 25°C for 15 min. The rectal temperature is then recorded as the initial rectal temperature. If the suit system is a dry suit system, the quantity of water determined in par. 6.22.1.1 shall then be added to the suit system. The subject dons and fully deploys the suit system as rapidly as possible without damaging the instrumentation, and immediately enters the water. The subject assumes a relaxed, floating position. No auxiliary means of buoyancy that is not part of the suit system may be used. The subject remains in the water, engaging in activity that maintains the heart rate between 50 and 140 beats per minute for the first hour, and 50 to 120 beats per minute thereafter, except that no attempt is made to control heart rate if the subject is shivering. Each temperature is recorded every 10 min. The test continues for 6 h from the time the subject first enters the water, unless it is terminated sooner.
- 6.22.2.1.4 **Termination of Test** — The test shall be terminated if
- the physician determines that the subject should not continue;
 - the subject requests termination due to discomfort or illness;
 - the subject's rectal temperature drops more than 2°C below the initial rectal temperature, unless the physician determines that the subject may continue without danger; or
 - the subject's finger, toe or buttock temperature drops below 8°C for more than 15 min and never below 5°C.
- 6.22.3 **Suit System Exterior Fabric Insulation** — The thermal conductivity of the exterior fabric of the suit system shall be less than or equal to that of a control sample of 4.75 mm thick, closed-cell neoprene foam when submerged at a depth of 1 m and tested as described in par. 6.22.3.1.1. The control samples of neoprene foam shall have a thermal conductivity of not more than 0.050 W/(m·K) as determined by ASTM C 177-04 or C 518-04.
- 6.22.3.1 **Insulation Test**
- 6.22.3.1.1 **Insulation** — The suit system material shall be tested as follows except that if the suit system exterior fabric meets the requirements for the control sample in par. 6.22.3.1.2 c., the test procedure in par. 6.22.3.1.3 is not required.
- 6.22.3.1.2 **Test Equipment** — The following equipment is required for the test:
- A sealed copper or aluminum can that has at least two parallel flat surfaces and contains at least 2 L of water and no air (see Figure 6).
 - A thermistor or thermocouple with an accuracy of $\pm 0.1^\circ\text{C}$ arranged to measure the temperature of the water inside the can.

- c. A control sample consisting of two flat pieces of 4.75 mm thick, closed-cell neoprene foam of sufficient size to enclose the can between them. The control sample shall have a thermal conductivity of not more than 0.050 W/(m·K). The thermal conductivity of the control sample shall be determined in accordance with ASTM C 177-04 or C 518-04.
- d. Two flat pieces of the suit system material of sufficient size to enclose the can between them. The surface covering, surface treatment, and number of layers of the material tested shall be the same as those of the material used in the suit system. If the material used in the suit system varies in thickness or number of layers, the material tested shall be representative of the portion of the exterior fabric of the suit system having the least thickness or number of layers.
- e. A clamping arrangement to form a watertight seal around the edges of the pieces of material when the can is enclosed inside. A sealing compound may be used (see Figure 7).
- f. A tank of water deep enough to hold the assembly of the can, material, and clamp arrangement at least 1 m below the surface of the water.
- g. A means to control the temperature of the tank of water between 0 and 1°C.
- h. A thermistor or thermocouple with an accuracy of $\pm 0.1^\circ\text{C}$ arranged to measure the temperature of the water in the can.

6.22.3.1.3 Test Procedure — The temperature of the water in the tank shall be between 0 and 1°C. The temperature of the water in the can shall be at 45°C. Hold the can under the water and clamp it between the two pieces of the neoprene foam control sample so that the assembly formed conforms as closely as possible to the shape of the can, and water fills all voids in the assembly. Submerge the entire assembly with the water temperature in the can at 45°C in the tank of water to a depth of 1 m at the highest point of the assembly. No part of the assembly shall touch the bottom or sides of the tank. Every 2 min, shake the assembly and then invert it from its previous position. Record the time for the water inside the can to drop from 45 to 33°C. Repeat this procedure three times using the suit system material instead of the neoprene control sample. The shortest time for the drop in water temperature when the suit system material is used shall be greater than or equal to the shortest time when the neoprene control sample is used.

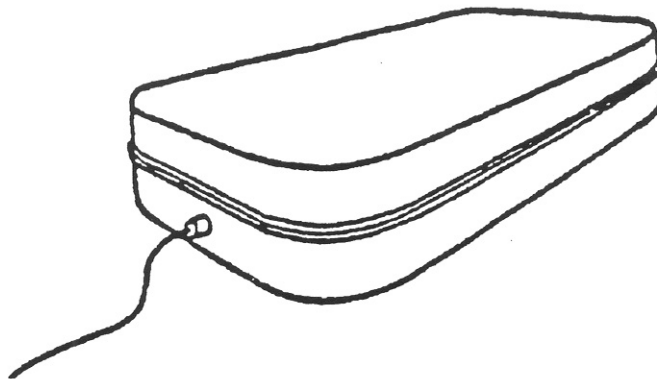

FIGURE 6

Water Can with Thermistor Lead

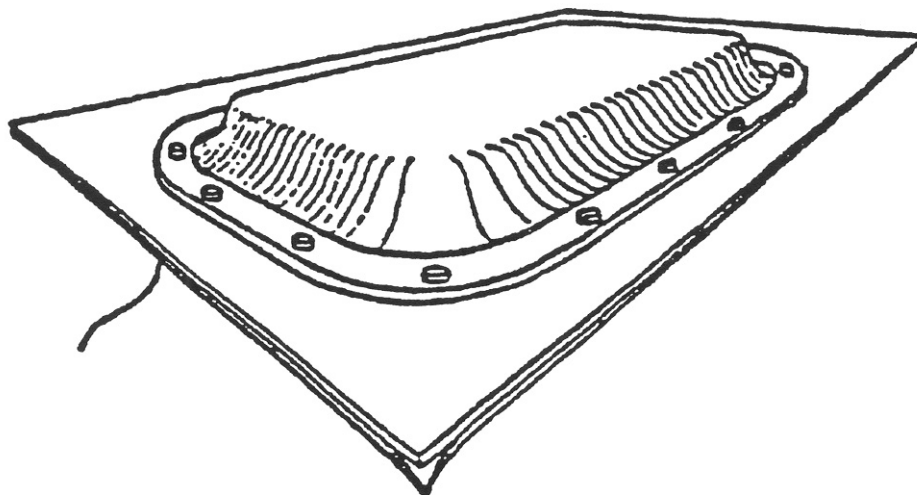

FIGURE 7

Insulation Test Assembly

(Assembly formed with water can, two pieces of material, and clamping device, with thermistor lead brought out of the assembly between the pieces of material.)

- 6.23 **Free Ends** — The excess length of any exterior belt or tie tape shall not exceed 100 mm when worn on a subject having a chest size at the lower limit of the indicated size range. Where the free end of an exterior belt or tie tape is sewn to form a loop, the loop shall not permit the passage of a rod 25 mm diameter.
- 6.24 **Buddy Line** — The suit system shall be equipped with a buddy line. It shall be stowed in such a way that it is easily visible and easily operable. The line shall not be less than 1 m and not more than 2 m in length when deployed. The line shall be attached to the suit system in such a way that if torn from the suit system, damage does not degrade the suit system's performance. The buddy line and attachments shall have a breaking strength greater than 400 N and less than 1340 N. The line shall have a snap hook attached at the free end to enable the wearer to connect to another wearer.
- 6.25 **Deck Safety Harness** — If a suit system incorporates a safety harness, it shall comply with the requirements of EN 1095:1998.

7. INSTRUCTIONS FOR USE

- 7.1 All instructions and marking shall be provided in English and French, primarily pictorial, with a minimum number of words. General information on the intended use of the suit system shall be readable at point of sale, including a description of the suit system, maintenance and cleaning instructions, instructions concerning the fitting and operation of a personal locator light, instructions of the operation of the inflatable element if any, and instruction on when and how to use it. The method of depicting proper donning procedures and other operational instructions on the use of the suit system shall be simple and obvious. The donning and wearing instructions shall be on the exterior of the storage container. These instructions shall also be available in a form suitable for mounting a bulkhead and insertion into the ship's training manual, where applicable.
- 7.2 The following information on the suit system shall be readable at point of sale:
 - a. The effectiveness of this suit system in preventing hypothermia and possibly death depends upon it fitting well enough to prevent the ingress of water;
 - b. Although the Universal size immersion suit system has been designed to fit the majority of individuals, the suit does not fit all body types equally well;
 - c. It is important that each person takes the initiative, where possible, to ensure the suit system they intend to wear in an emergency is of a proper size and watertight;

- d. A description of the suit system;
- e. Maintenance and cleaning instructions;
- f. Instructions concerning the fitting and operation of a personal locator light; and
- g. Instructions of the operation of the inflatable element if any and instructions on when and how to use it.

7.3 The method of depicting proper donning procedures and other operational instructions on the use of the suit system shall be simple and obvious. The donning and wearing instructions shall be on the exterior of the storage container. These instructions shall also be available in a form suitable for mounting a bulkhead and insertion into the ship's training manual, where applicable.

7.4 The manufacturer shall provide written instructions for the care and maintenance of the suit system. Any relevant information concerning the operation of the accessories specific to the suit system, and the operation of the personal locator light shall also be provided. Instructions on the operation of the inflatable buoyancy element, if any, shall be readable in the water in low-level illumination.

8. MARKING

8.1 Each suit system shall be marked or labelled legibly and permanently with the following information:

Name, logo, or trademark of the manufacturer

Category of immersion suit system

Model number

Date of manufacture

Size (for Marine Abandonment Immersion Suit Systems, mark in block letters not less than 25 mm high)

Size range (height and weight, or both)

Thermal protection as immersed clo value

Lot number

Serial number, if assigned

Statement of compliance: "This suit system complies with the requirements of CAN/CGSB-65.16-2005."

Note: Manufacturers should be aware that in Canada the Administration having jurisdiction, Department of Transport, requires that the approval number on immersion suit systems be clearly marked with approval information, including the Administration that approved it and any operational restrictions.

8.2 The size markings for the child size suit system and storage container, if any, shall include

- a. the statement "CHILD (PERSON UNDER 40 kg)"; and
- b. a child pictogram conforming to that of IMO Resolution A.760(18). The pictogram (see Figure 8) shall be a minimum of 38 mm high.

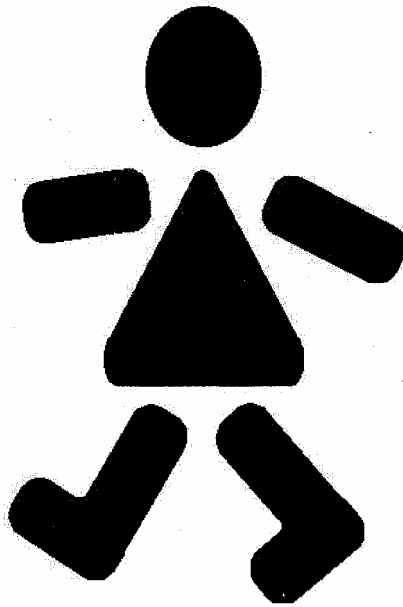

FIGURE 8

Child Pictogram

- 8.3 **Logos, Appliqués and Lettering** — Markings may be stitched, silk-screened, heat-sealed, or adhered to the exterior fabric such that they do not
- affect the integrity of the device;
 - affect the visibility or readability of the required markings; and
 - provide any information contradicting the required markings.
- 8.4 Each storage container, where applicable, shall be marked with the following information:
- The words “IMMERSION SUIT”
 - Size range
 - Donning instructions
- 8.5 Any suit, as well as its stowage bag or container, that is intended for constant wear only, or any marine abandonment suit that is sized other than “Universal,” shall be conspicuous and permanently marked with the following words in characters at least 10 mm high.

WARNING

THIS SUIT HAS A LIMITED SIZE RANGE AND IS NOT SUITABLE FOR UNCONTROLLED EMERGENCY DISTRIBUTION

9. NOTES

9.1 Sources of Referenced Publications

The following addresses were valid at the date of publication.

- 9.1.1 The publications referred to in par. 2.1.1 may be obtained from the Canadian General Standards Board, Sales Centre, Gatineau, Canada K1A 1G6. Telephone (819) 956-0425 or 1-800-665-2472. Fax (819) 956-5644. E-mail ncr.cgsb-ongc@pwgsc.gc.ca. Web site www.ongc-cgsb.gc.ca.

- 9.1.2 The publications referred to in par. 2.1.2 may be obtained from ASTM International, 100 Barr Harbor Drive, West Conshohocken, PA 19428-2959, U.S.A. or from IHS Canada, 1 Antares Drive, Suite 200, Ottawa, Ontario K2E 8C4, telephone (613) 237-4250 or 1-800-267-8220, fax (613) 237-4251, Web site www.global.ihs.com.
- 9.1.3 The publication referred to in par. 2.1.3 may be obtained from IHS Canada, 1 Antares Drive, Suite 200, Ottawa, Ontario K2E 8C4. Telephone (613) 237-4250 or 1-800-267-8220. Fax (613) 237-4251. Web site www.global.ihs.com.
- 9.1.4 The publications referred to in par. 2.1.4 may be obtained from the International Maritime Organization (IMO) Publications Section, 4 Albert Embankment, London SE1 7SR, United Kingdom. Web site www.imo.org.
- 9.1.5 The publications referred to in par. 2.1.5 may be obtained from Comm 2000, 1414 Brook Drive, Downers Grove, IL 60515, telephone (415) 352-2168, fax 1-888-853-3512, Web site www.comm-2000.com or from IHS Canada, 1 Antares Drive, Suite 200, Ottawa, Ontario K2E 8C4, telephone (613) 237-4250 or 1-800-267-8220, fax (613) 237-4251, Web site www.global.ihs.com.